



ULTRA-LOW POWER INFRARED GAS SENSOR MIPEX-04-X-XX-3.1



Features

- ☑ Target application: clip combustible gas detectors for industrial safety.
- ☑ Allows designing clip gas detector lasting no less than 24 months without charge.
- ☑ Lowest available power consumption among combustible gas sensors. Average operating current is less than 35 microAmps.
- ☑ Smart sensor with embedded microcontroller returns linearized, temperature-compensated output data.
- ☑ Measurement range up to 100% vol. for methane (CH₄) or up to 2.5% vol. for propane (C₃H₈).
- ☑ Provides intrinsically safe explosion protection level “ia” which does not need metal-ceramic filters (sinters).

Description

MIPEX-04 is intended for automatic continuous measurement of hydrocarbons concentration in atmosphere of hazardous areas.

Sensor operating principle is based on NDIR technology, i.e. on selective absorption of LED produced infrared radiation by gas molecules.

Differential dual wavelength method allows eliminating of water vapor, optical elements contamination and other non-selective hindrances influence.

Communication interface – UART.

Technical specification

General specification		
Gas sampling method:	Diffusion	
Operating principle:	Non-Dispersive Infra-Red (NDIR)	
Target gas	CH ₄	
	C ₃ H ₈	
Operating, storage and transportation conditions:	Relative humidity, %	up to 98
	Atmospheric pressure, kPa	80...120
	Temperature*, °C	-40...+60
Warm-up time, sec	≤ 120	
Overall dimensions, mm	52×24×18	
Housing material	Polycarbonate Lexan™	
Weight, g	11.0...13.5	

Measurement specification	
Measurement range, % vol.	0...2.5
	0...5
	0...100
Variability (+20...+25 °C)**	± 0.1% vol. or ± 5% of readings (whichever is greater) for CH ₄
	± 0.05% vol. or ± 5% of readings (whichever is greater) for C ₃ H ₈
Response time t(90), sec	< 30 (CH ₄ sensors)
	≤ 45 (C ₃ H ₈ sensors)

Electrical specification	
Operating supply voltage, VDC	+2.8...+5.0
Maximum supply voltage, VDC	+5.5
Communication interface	UART
Average current, µA	25...35 max at normal conditions
	40 max at -40...+60 °C
Peak current, mA	2 max

* Term **operating temperature** refers to ambient temperature at which sensor operates and its intrinsic safety is ensured, but sensor readings variability is provided only in specified **temperature range**.

** Variability in whole operating temperature range for any sensor modification is presented below.

Calibration gas	Readings variability within a temperature range	Additional variability due to pressure	Additional variability due to humidity
CH ₄	± 0.1% vol. or ± 5% of readings within the range of +20...+25 °C;	± 0.2% vol. or ± 30% of readings at 100 kPa (test: 80 kPa, 100 kPa, 120 kPa)	± 0.2% vol. or ± 15% of readings (whichever is greater) at 40 °C and 0% RH (test: 20% RH, 50% RH, 90% RH)
	± 0.2% vol. or ± 10% of readings within the range of -10...+20 °C and +25...+40 °C;		
	± 0.4% vol. or ± 20% of readings within the range of -40...-10 °C and +40...+60 °C.		
C ₃ H ₈	± 0.05% vol. or ± 5% of readings within the range of +20...+25 °C;	± 0.1% vol. or ± 30% of readings at 100 kPa (test: 80 kPa, 100 kPa, 120 kPa)	± 0.1% vol. or ± 15% of readings (whichever is greater) at 40 °C and 0% RH (test: 20% RH, 50% RH, 90% RH)
	± 0.1% vol. or ± 10% of readings within the range of -10...+20 °C and +25...+40 °C;		
	± 0.2% vol. or ± 20% of readings within the range of -40...-10 °C and +40...+60 °C.		

Ordering info

Part number structure:

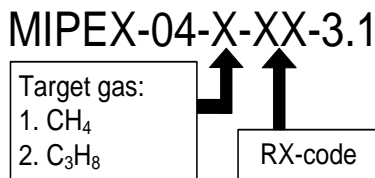

Term **target gas** refers to LED and photodiode spectral range which is adjusted for best detection of a certain gas, while term **calibration gas** refers to gas mixture used for sensor calibration.

RX-code refers to measurement range, calibration gas and temperature range.

Part number	Target gas	Calibration gas	Measurement range, % vol.	Temperature range, °C	RX-code	
MIPEX-04-1-00-3.1	CH ₄	CH ₄	0...2.5	-10...+40	00	
MIPEX-04-1-10-3.1			0...5		10	
MIPEX-04-1-20-3.1			0...100		20	
MIPEX-04-1-01-3.1			0...2.5	-40...+60	01	
MIPEX-04-1-11-3.1			0...5		11	
MIPEX-04-1-21-3.1			0...100		21	
MIPEX-04-1-02-3.1		0...2.5	-20...+50	02		
MIPEX-04-1-12-3.1		0...5		12		
MIPEX-04-1-22-3.1		0...100		22		
MIPEX-04-1-61-3.1		C ₃ H ₈	C ₃ H ₈	0...1.5	-40...+60	61
MIPEX-04-1-71-3.1				0...2.5		71
MIPEX-04-1-62-3.1				0...1.5	-20...+50	62
MIPEX-04-1-72-3.1	0...2.5		72			
MIPEX-04-2-61-3.1	C ₃ H ₈		C ₃ H ₈	0...1.5	-40...+60	61
MIPEX-04-2-71-3.1				0...2.5		71
MIPEX-04-2-62-3.1		0...1.5		-20...+50	62	
MIPEX-04-2-72-3.1		0...2.5			72	

Typical sensor cross-sensitivity to hydrocarbons and accuracy

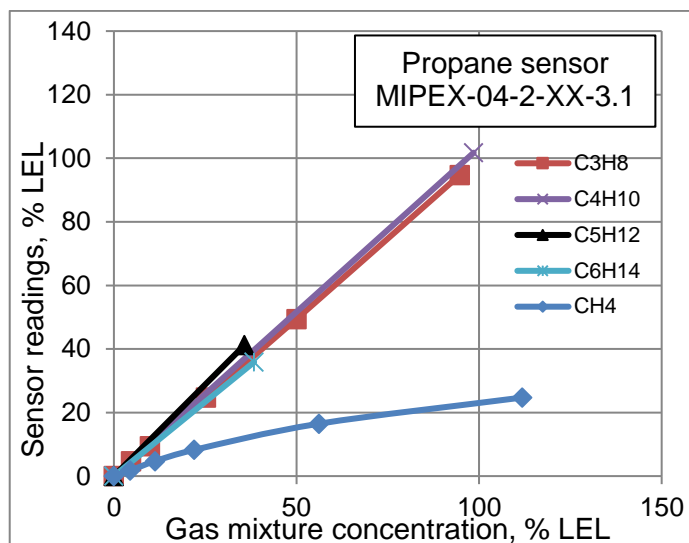
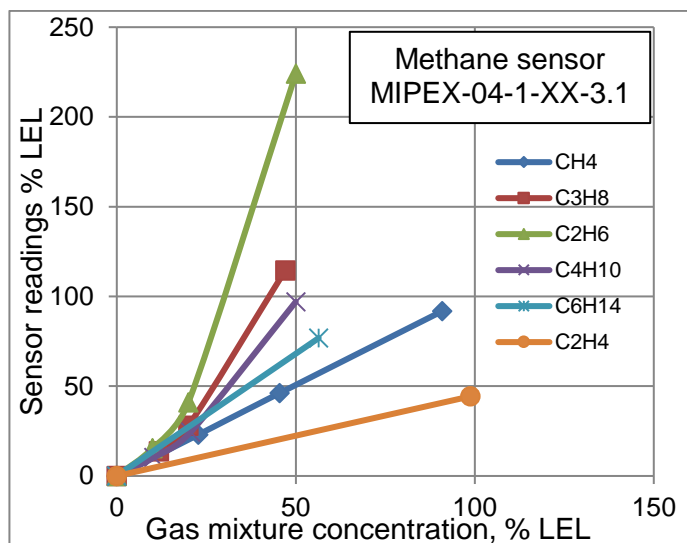

Current consumption

Average current consumption is not more than 35 μ A when request rate is less than 1 Hz.

Intrinsic safety

Sensor complies with IEC/EN 60079-0 and IEC/EN 60079-11:

- Explosion protection level – “ia”;
- Hazardous area class (Electrical equipment group) – “I” and “IIC”;
- Intrinsic safety parameters: $P_i = 0.13$ W, $U_i = 5.5$ V, $I_i = 200$ mA, $C_i = 26$ μ F, $L_i = 0$.

Sensor is suitable for use within end equipment with temperature classes T1-T6 at maximum ambient temperature of +60 °C.

Marking and cert. numbers

MIPEX-04 has IECEx/ATEX certification when the logo  is present on the sensor.

MIPEX-04 has certification for US and Canada when the logo of Nationally Recognized Testing Laboratory (NRTL) is present on the sensor.

The details of IECEx/ATEX and ETL certification are specified in Appendix B of User Manual (Fig. 8. Intrinsic safety control drawing).

Handling precautions

Maximum pressure load to sensor top surface must not exceed 0.27 N/mm².

It is not allowed to apply pressure to side surface.

Sensor is not intended to measure hydrocarbons contained in water or other fluids.

Gas holes of sensor should be protected against ingress of dust and sprayed materials.

There is no risk of pollution and negative impact on human health. Sensor does not contain any harmful substances that may be released during its normal operation.

Sensor pinout

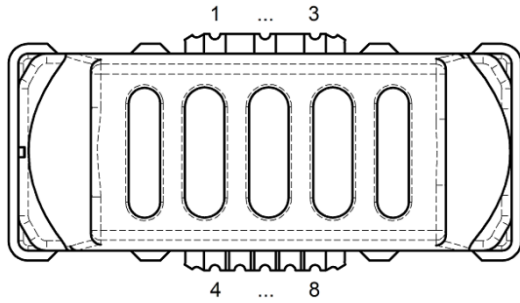

Pin	Purpose
1-3, 7	GND
4	UART Tx out
5	UART Rx in
6	Empty
8	+2.8...+5.0 VDC

Recommended mating board configuration (sensor side shown)

All dimensions are in millimeters.

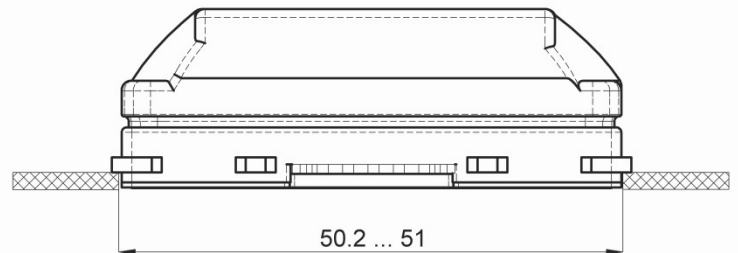
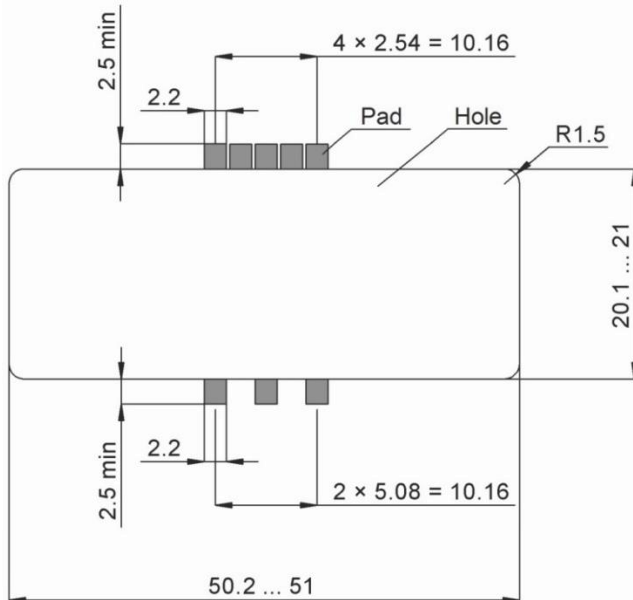

Contacts

MIPEX TECHNOLOGY

SIA MIPEX

2B, Valkas iela, Daugavpils, Latvia, 5417

Tel/fax: [+371 26179021](tel:+37126179021)

web: www.mipex-tech.com

e-mail: info@mipex-tech.com

support: support@mipex-tech.com